

Installation and Operating Instructions

Typ HDK

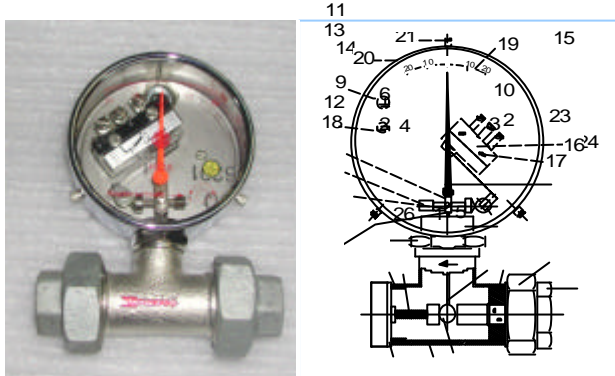

Installation: Installation horizontal wherever possible on the basis of shematic 1, 2 or 3, only pressure line, not suction side since the seal of the control shaft 5) is not vacuum-tight. However, the monitor may be subject to temporary depressurization. It is also possible to install the monitor in a vertical line with rising or falling flow, please refer to shematics 3 and 4.

The line must be flushed before installation, particularly if not dirt traps are to be fitted.

Shut-off valves upstream of the dirt trap and downstream of the HDK if the former needs to be cleaned under pressure.

Electric connection: This must be carried out in accordance with VDE regulations or a power supply company protective earthing system must be provided.

Contact setting: If not otherwise specified in the order, the monitors are tested with cold water and the most frequent connection (operating current) is set on which the contact breaks when the flow rate decreases.

Size: I OFF at 20 l/h II OFF at 100 l/h III OFF at 200 l/h IV OFF at 600 l/h

Changing the setting: Remove the bezel (20) and scale disc (19). Beforehand, note down the pointer deflection on the scale in angular degrees. Unlock the regulating screw (13) with adjusting screw (14). The distance of the pointed cone with respect to the roller on the microswitch is reduced or increased by rotating in a clockwise or counter-clockwise direction respectively. This changes the switch-on and switch-off point, referred to the flow rate.

Number of turns of the regulating screw (13) from minimum to maximum flow:

Size I 4,5 II 4,5 III 5,0 IV 7,0 turns

1/6 of a turn of the regulating screw changes the liquid flow switching value + or - :

Size I by approx.37 l/h II by approx.92 l/h III by approx.166 l/h IV by approx.430 l/h

Air and Gas necessitate experimental adjustment or precise ordering information for setting on the JLSO.

Precise flow switching values necessitate an upstream measuring instrument or discharge measurement with graduated vessel.

Local conversion of the installation position: from h/l 1) to h/r or vice versa

1. Open the switch housing, 2. Remove the microswitch and screw in the clamping screws at the opposite, 3. Slacken the lock nut (12), unscrew the cross nut (11) with pointer, rotate the regulating screw (13) by unscrewing the pointed cone with a pair of flat-nosed and cutting pliers, 4. Slacken the retaining nut (10), rotate the switch-housing (9) by 180° degrees, tighten the nut (10). 5. Reserve the positions of the screw and dummy screw (18) M3, 6. Refit the cross nut with pointer, align it to the scale zero point. 7. Fit the microswitch and check the function by hand at the spool pilot pins (3).

If you still have questions as regards the arrangement, circuit and wiring: Please inquire with us stating precise operating conditions such as the pump data, installation plan and circuit diagram.

Please note during operating: If the line pressure remains constant, the flow rate switch point and pointer deflection must remain constant. Blockages may occur as the result of desposits and corrosion on the inside parts which come in to contact with the media. These blockages can be cleared by removing the flow monitor and flushing it through with dilute acid.

Ordering information: 1. Intended application, 2. Medium, 3. Stagnation pressure and operating pressure, 4. Temperature, 5. Line diameter R", 6. Flow rate at switch point ON or OFF in l/h, 7. Installation position in accordance with shematics 1, 2, 3, 4.

Spare parts: In accordance with rating plate, type, order-number, year of delivery.

Copyright © Jlso Tec Trade GmbH

JLSO Tec Trade GmbH
Südring 41

Daniel H. Meckel
76761 Rülzheim

Fon: 0721 – 51 658-64
info@jlso-tec-trade.de

Fax: 07272 / 9 738 484
http://jlso-tec-trade.de